

SerieR

V16/18
V22
V25
V30

F22
F28

R32
R40
R45

TCS
DIGIT
AUTOMAX

VFRHT

S E R I E



R32
R32E
R40
R40E
R45
R45E

CE



SERRMÄC

R32

Bohrmaschine der Reihe Mittelschwer mit Hochleistungsgetriebe



EIGENSCHAFTEN



Automatischer Spindelvorschub, mechanisch



TR: 600 x 345 mm
Grundplatte



PGM: 325 x 325 mm
Schwenkbare Grundplatte mit
eingebautem Schraubstock

SERRMAC



TR

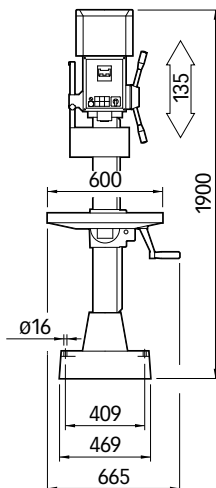
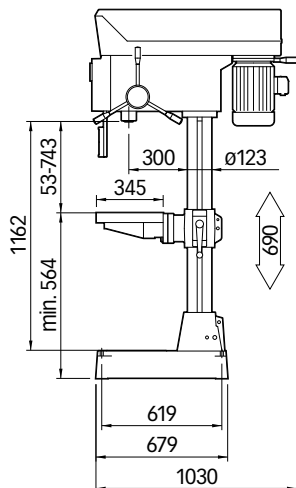

PGM

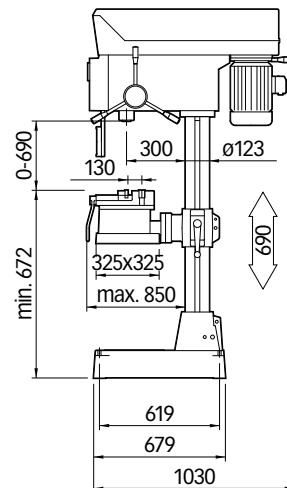

R32E

Bohrmaschinen der Reihe Mittelschwer mit Hochleistungsdrehzahlregelung

Inverter



EIGENSCHAFTEN



Automatischer
Spindelvorschub, mechanisch

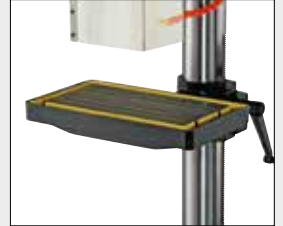

TR: 600 x 345 mm
Grundplatte



PGM: 325 x 325 mm
Schwenkbare Grundplatte mit
eingebautem Schraubstock

SERRMÄC

CE  MADE IN ITALY

TR

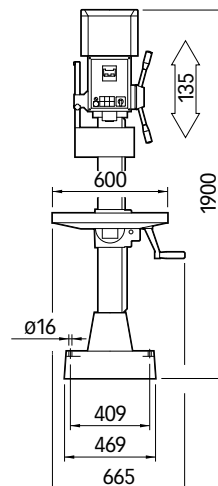
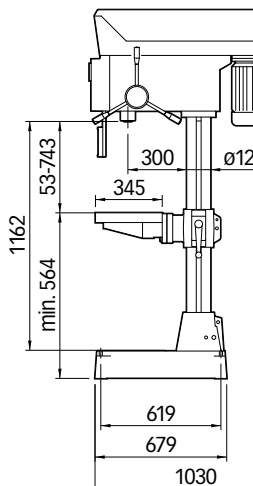

PGM

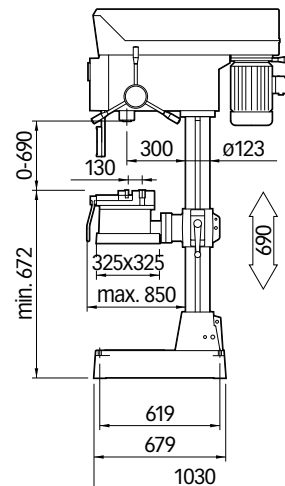

R40

Bohrmaschinen der Reihe Mittelschwer mit Hochleistungsdrehzahlregelung

Spindelpinole MK 4 mit Gewinde für die Werkzeugblockierung

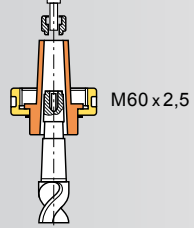
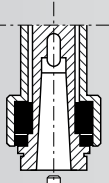

EIGENSCHAFTEN

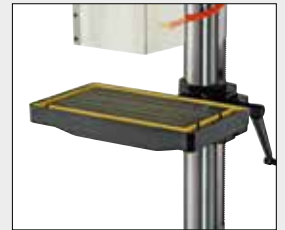

TR: 600 x 345 mm Grundplatte



PGM: 325 x 325 mm Schwenkbare Grundplatte mit eingebautem Schraubstock



TC: 630 x 255 mm Kreuztisch

SERRMAC



TR

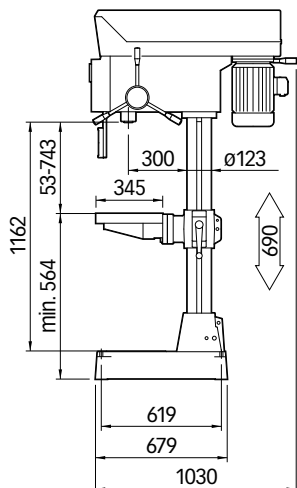

PGM

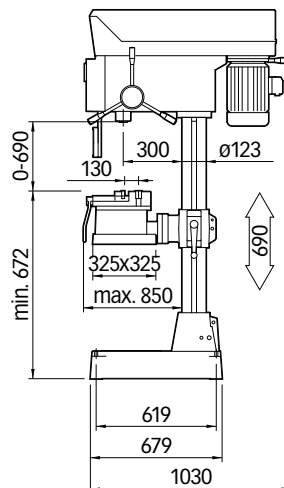

TC

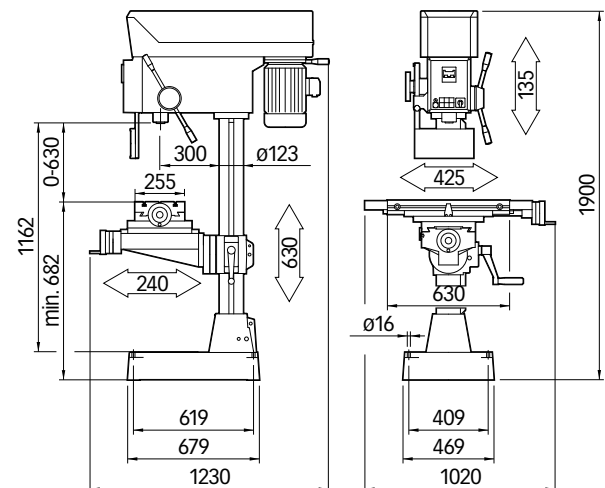

R40E

Bohrmaschinen der Reihe Mittelschwer mit Hochleistungsdrehzahlregelung

Inverter



Spindelpinole MK 4 mit Gewinde für die Werkzeugblockierung

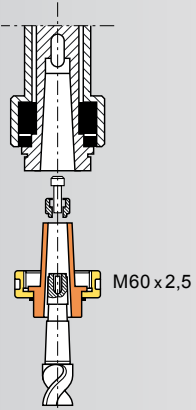

EIGENSCHAFTEN

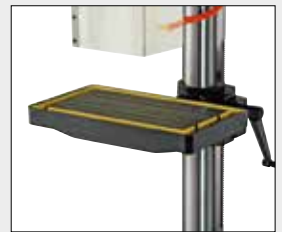

TR: 600 x 345 mm Grundplatte



PGM: 325 x 325 mm Schwenkbare Grundplatte mit eingebautem Schraubstock



TC: 630 x 255 mm Kreuztisch

SERRMAC

CE  MADE IN ITALY

TR

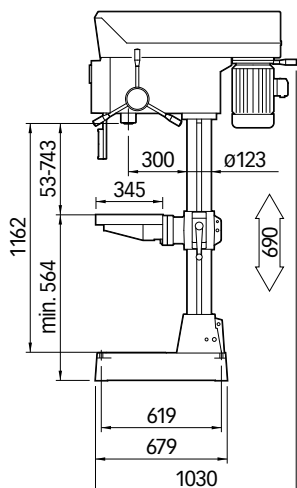

PGM

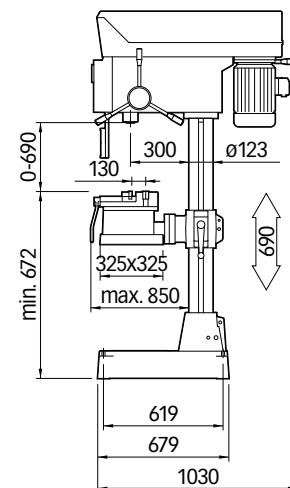

TC

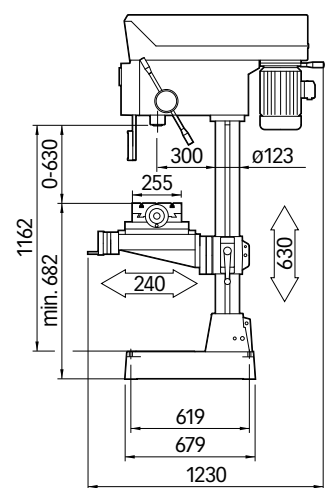
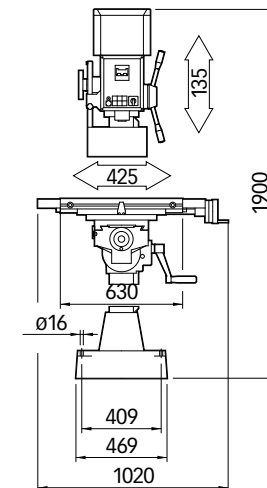

Spindelpinole MK 4 mit Gewinde für die Werkzeugblockierung

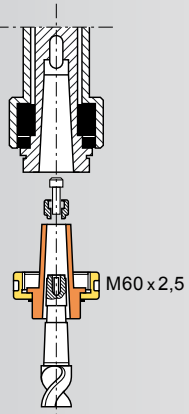

EIGENSCHAFTEN



Standard: Automatisch-mechanischer Spindelvorschub



TR: 600 x 460 mm Grundplatte



PGM: 375 x 375 mm Schwenkbare Grundplatte mit eingebautem Schraubstock



TC: 630 x 255 mm Kreuztisch



TR

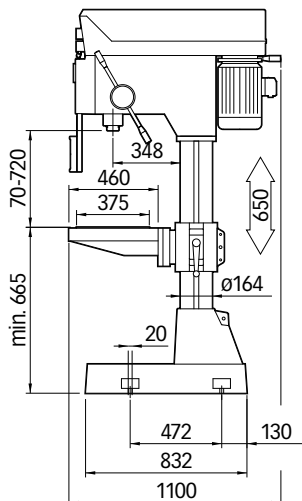

PGM

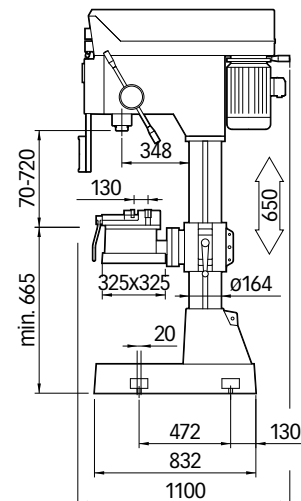

TC

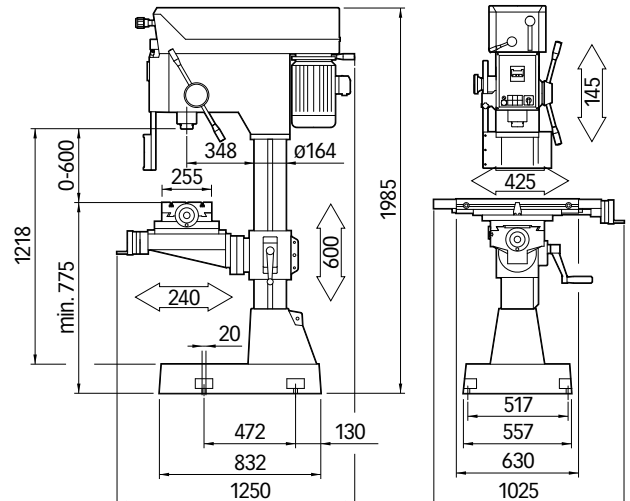

R45E

Säulenbohrmaschine der Reihe Schwer Drehzahlverstellung: Elekt. Variator

Inverter



Spindelpinole MK 4 mit Gewinde für die Werkzeugblockierung

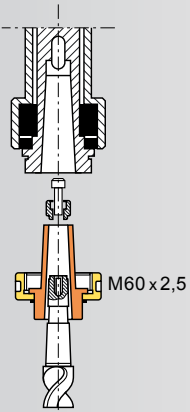

EIGENSCHAFTEN



Standard: Automatisch-mechanischer Spindelvorschub



TR: 600 x 460 mm Grundplatte



PGM: 375 x 375 mm Schwenkbare Grundplatte mit eingebautem Schraubstock



TC: 630 x 255 mm Kreuztisch



TR

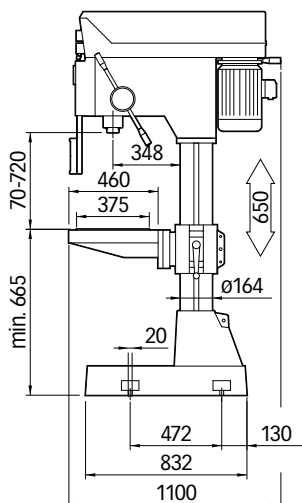

PGM

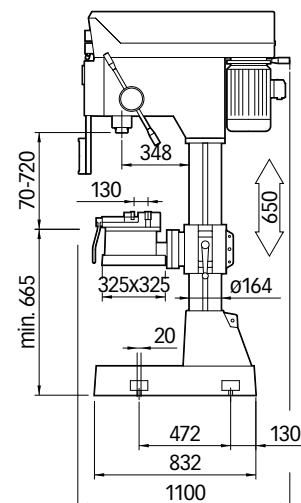

TC

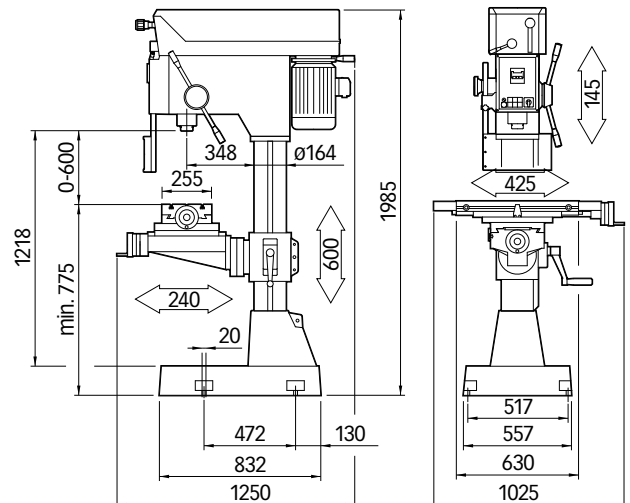

OPTIONEN



Code 40022: LED
–Maschinenleuchte 24 Volt



Code 30001: Kühlmittelaggregat.



Code 40002: Gewindeschneideeinrichtung mit Drehrichtungswender



Code 40024: Digitale Drehzahlanzeige



Code 30018: Flow drill.

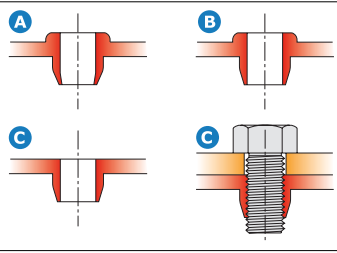
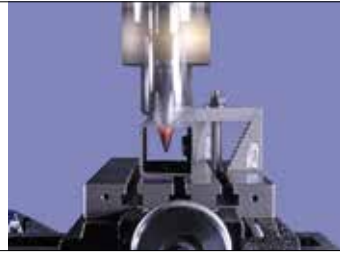

Code 30003: Automatisch-mechanischer Spindelvorschub (Option) 3 Geschwindigkeiten: 0.05 – 0.1 – 0.2 mm/U (R32 – R40).

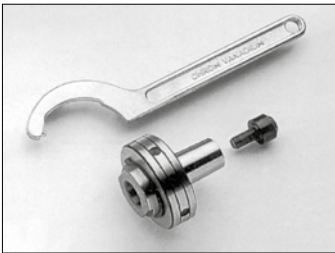

Code 39000050/60/70:
Innenspannaufnahme mit Sicherungsring für Schaftfräser auf Anfrage: MK 1-2-3

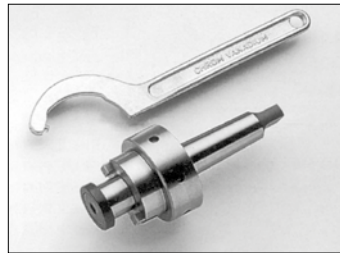

Code 39000010/20/30/40:
Spannaufnahme mit Sicherungsring für Planfräser auf Anfrage: \varnothing 16-22-27-32 mm



Code 9460009: Fräterspannfutter mit Spannzangen: \varnothing 4–6–8–10–12–16–20.

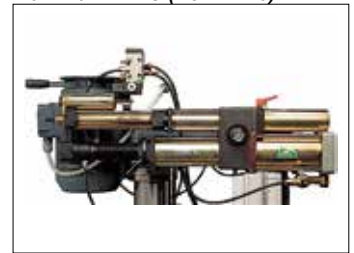

Code 30019: Hydro-pneumatischer Spindelvorschub UR80 (R 32-R40)
Code 40010: Hydro-pneumatischer Spindelvorschub UR100 (R45)
Automatischer Spindelvorschub von 105 mm mit schnellem Rücklauf auf die eingestellte Tiefe.
Vorschub: 5 – 2.500 mm/min.
Schubkraft: bei 6 bar = 4000 N.

R45 - R45E

OPTIONEN



Code 0083:
Automatischelektromagnetischer Spindelvorschub 24 Dc (für TCS).



Code 40025: Digitalanzeige für X und Y Achsen



Code 40026 Power: Automatisch-mechanische Tischlängenverstellung



Code 40006: Eilgang für die Tischhöhenverstellung



Code 40001: Verlängerter Spindelhub 230 mm (nur mit VS).



Code 40020: Bohrspindel mit Morsekonus ISO 40 und Anzugstange (DIN 2080).



Code 40037: MK4 Hohlspindelachse

SerieR

R32
R32E
R40
R40E
R45
R45E
TECHNISCHE DATEN

Bohrvermögen Stahl R50	mm	ø 32		ø 32		ø 40		ø 40		ø 45		ø 45			
Gewindeschneideleistung Stahl R50	mm	M 20		M 20		M 24		M 24		M 26		M 26			
Spindelaufnahme		MT3		MT3		MT4		MT4		MT4		MT4			
Spindelhub	mm	135		135		135		135		145		145			
Pinolendurchmesser	mm	62		62		62		62		72		72			
Automatisch- mechanischer Spindelvorschub (Option)		3 Geschwindigkeiten:: 0.05 – 0.1 – 0.2 mm/U													
Aut. Spindelvorschub mit elektomech. Kupplung		–		–		–		–		3 Geschwindigkeiten: 0.05 – 0.1 – 0.2 mm/U		--			
Säulendurchmesser	mm	123		123		123		123		164		164			
Tisch		PG – PGM – TR		PG – PGM – TR		PG – PGM – TR – TC		PG – PGM – TR – TC		PGM – TR – TC		PGM – TR – TC			
Getriebe		PU	VS	Inverter		PU	VS	VR	CI	Inverter		VS	VR*	CI* N° 12 Sp.	Inverter
Spindeldrehzahlen	rpm	100 – 2.200	100 – 1.640	100 – 2.000		100 – 2.200	100 – 1.640	*64 – 2.380	64 – 1.720	45 – 900 / 110 - 2150		100 – 1.650	64 – 2.340	50 – 1.300	45 – 900 / 110 - 2150
Motorleistung (380 V 50 Hz)	kW	1.1 – 1.84		2.2		1.1 – 1.84	1.1 – 1.84	2.2	1.1 – 1.84	2.2		2.2 – 3	2.2	2.2 – 3	3
T – Nutenabstand	mm	125		125		125		125		125		200 (TR) – 160 (TM)		200 (TR) – 160 (TM)	
T – Nutenabmessung	mm	14		14		14		14		14		14		14	
Kreuztisch: manueller Längsvorschub X Achse	mm	–		–		425		425		425		425		425	
Kreuztisch: automatischer Längsvorschub X Achse	mm	–		–		365		365		365		365		365	
Kreuztisch: manueller Quervorschub Y Achse	mm	–		–		240		240		240		240		240	
Säulenabmessungen (H x B x T)	mm	1.900 x 665 x 1.030		1.900 x 665 x 1.030		1.900 x 665 x 1.030		1.900 x 1.020 x 1.230 (TC)		1.986 x 675 x 1.100		1.986 x 675 x 1.100		1.986 x 675 x 1.100	
Gewicht	Kg	370		370		410		410		410		548 (TR) – 610 (TC)		548(TR) - 610(TC)	

* R40 VR optionen: motor 1.1/1.84 kW - 32/2.380 rpm * R45 VR optionen: motor 2.2/3 kW - 32/2.340 rpm * R45 CI optionen: motor 2.2/3 kW - 64/1.720 rpm.

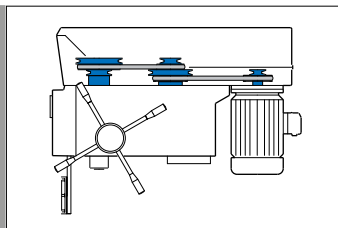
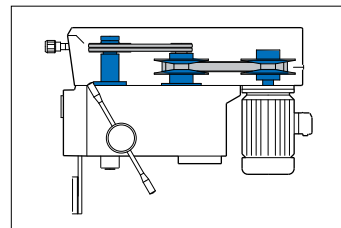
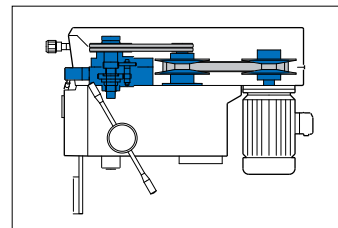
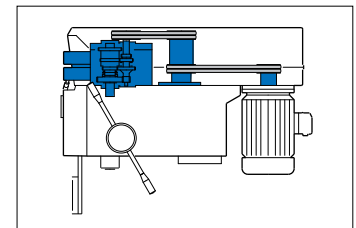
R32 – R40
R32 – R40 – R45
R40 – R45
R40 – R45
GETRIEBE

PU: Stufenscheiben

VS: Stufenloser Geschwindigkeitsregler

VR: Stufenloser Geschwindigkeitsregler mit zweistufig gem Schaltgetriebe.

CI: Schaltgetriebe

VS: Stufenloser Geschwindigkeitsregler

VR: Stufenloser Geschwindigkeitsregler mit zweistufig gem Schaltgetriebe

CI: Schaltgetriebe.



Maschinen Härtel GmbH & Co. KG

Maschinen für ihre Fertigung

Tel: +49-212-64 544 81-0

Fax: +49-212-64 544 81-1

Eichenstraße 65

42659 Solingen , Deutschland

Beratung + Service +49-212-880 79 69 5

www.maschinen-haertel.de

Maschinen@haertel.group